

Syngas Production from Date Palm Seeds by Using Advanced Microwave Technology

N. Al-Rubaye¹, D. Al-Khafagi¹, B. Kabalan², and A. Al-Shammaa^{1,2}.

¹ University of Babylon, College of Engineering, Babylon, Iraq

² Liverpool John Morris University, BEST Research Institute, School of Built Environment, UK

Abstract

This paper deals with syngas production from date palm seeds. Microwave plasma technology was used to pyrolysis them and produce syngas. Three samples of date palm seeds were used: *full*, *crushed*, and *powdered* with different flow rate of argon to increase the concentration of plasma. The results show that there is no need to pre-treat (mill) the date palm seeds to improve biogas production process; besides, the reduction of argon flow-rate has yielded better percentage of biogas production.

Keywords: gasification, date palm seeds, syngas, microwave, plasma.

Introduction

Over 44,000 tons of dates are annually produced in Iraq [1]. Current dates' seeds disposal methods include using it as livestock fodder, or burning it to produce heat. This combustion process is not environmentally friendly and is not very economically useful.

Bio-oils are typically produced by pyrolysis processes, wherein the biomass is heated in the absence of oxygen [2]. The general definition of gasification is the conversion of any carbonaceous feedstock "fuel" to gaseous products using partial oxidation. The main product of this partial oxidation is synthesis gas or syngas; it consists of hydrogen (H₂) and carbon monoxide (CO). The Syngas is later cleaned-up and further processed to produce chemicals, fertilisers, liquid fuel and electricity [3]. The feedstock that is converted to syngas can be derived from hydrocarbon materials. Coal was the first feedstock to be used in the gasification process, but due to demand of sustaining the earth resources, other types of feedstock are being used; biomass is in use at the moment which includes corn stover, sawdust, and wood [4]. Feedstock's undergo several chemical reactions to produce syngas, some of which are exothermic and some are endothermic [5]. Gasification technology gives the advantage of getting energy from a low cost and otherwise useless waste, and recycles it at the same time. Gasification is similar to combustion, but it is considered a partial combustion process, and it has smaller carbon dioxide (green house gas) emission [6].

Microwave technology is one of many methods that are used to pyrolysis waste because it has many advantages, such as: energy efficiency, rapid and controlled heating, and the ability to operate from an electrical source. A number of studies have investigated the feasibility of using microwave heating instead of conventional heating for pyrolysis processes. Dominguez *et al.* [2] used small coffee hulls to produce methane (CH₄). On the other hand, Beszedes *et al.* [7] have used microwave treatment to increase the biodegradability of canned maize. Similarly, Robinson *et al.* [8] have used wood as raw material to produce biogas by microwave technology.

Another method used to achieve the same goal is that of *anaerobic digestion*, which is a biological process that happens naturally when bacteria breaks down organic matter in environments with little or no oxygen [9]. Pound *et al.* [10] used anaerobic digestion process to produce biogas from a mixture of cattle slurry and a different ratio of pressed sugar-cane stalk. Another anaerobic digestion method was used by Momoh *et al.* [11] with different materials such as: cow dung, waste paper, and water hyacinth. Another study was carried out by Basri and *et al.* [12] who examined the effect of the organic loading rate (OLR) on the production of biogas from palm oil mill effluent. To our knowledge, no one has used date palm seeds as a raw material in pyrolysis by using microwave plasma gasification technology to produce syngas.

The object of this study is to produce a renewable energy from waste. Date palm seeds have been tested as a raw material with three different forms and with three different flow rates of argon to achieve this aim.

MATERIALS and METHODS

Raw date palm seeds were obtained from Babylon, Iraq. Tree samples were used: date palm seeds with ordinary shape (full), crushed palm seeds, and powdered palm seeds, each of them had a weight of 30g. (See Fig. 3). Crushed seeds and powdered seeds were milled by a hand hammer. All experiments were conducted at BEST Research Institute, John Morris University in Liverpool, UK. Biomass gasification is an endothermic conversion technology where a solid fuel is converted into a combustible gas [13]. The gasification system, figure (2), consists of a magnetron power supply, a circulator, a water-cooled matched load, a tuning system (E-arm and H-arm), a plasma cavity (which contains a nozzle where the plasma is created using argon) and the gas chamber. The creation of the plasma is achieved by using a microwave power source (1.1KW, 2.45 GHz) and argon gas passing through the nozzle inside the chamber. When the electric field is strong enough at the nozzle, argon molecules are ionised and argon is turned to plasma [14]. Figure (1) below shows the gasification system block diagram:

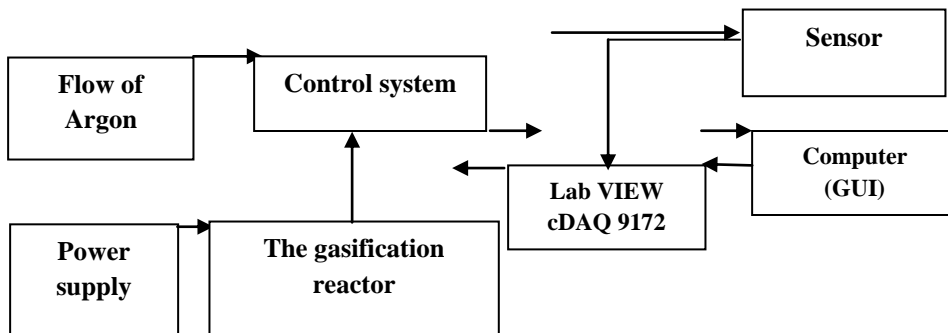

Fig (1) Gasification System Block Diagram.

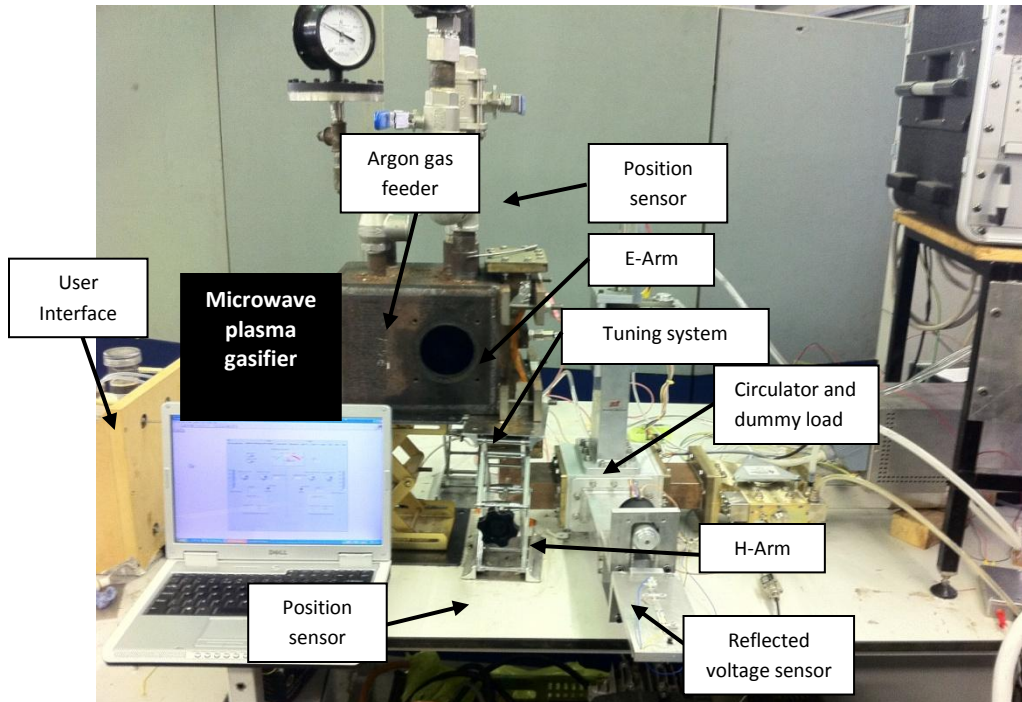
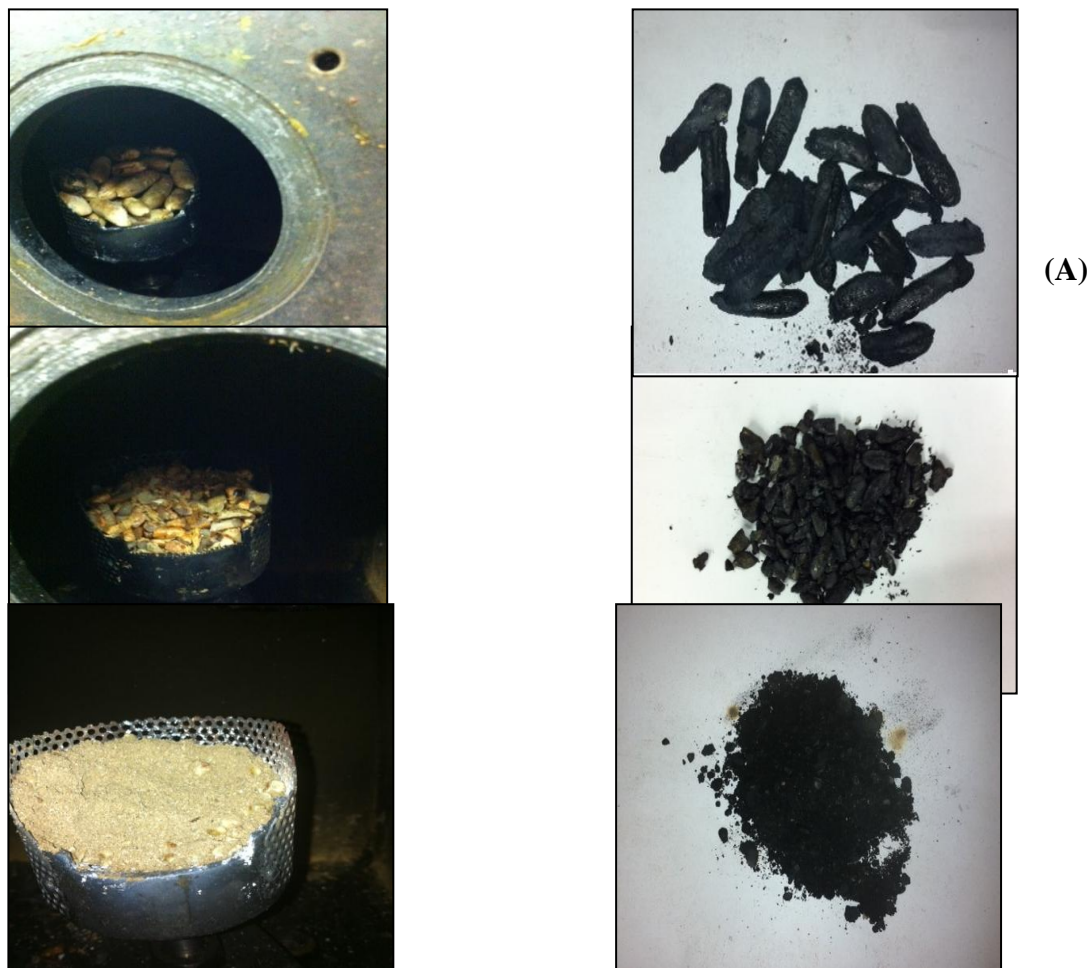

Fig (2) Overview of the gasification System.

Laboratory Virtual Instrument Engineering Workbench (LabVIEW) – which is a graphical programming language that uses icons instead of lines of text to create programs – was used to reduce reflected power automatically and record the results. Each sample was exposed to plasma flow with three different flows of Argon (*1, 0.5, and 0.25*) L/min. The reduction of Argon rate had a large influence on biogas production, especially with the second and third samples. In general, there has been a direct relationship between biogas production and reduction of Argon flow.



**Fig (3) Samples before (left) and after (right) Gasification Process:
(A) Full form, (B) Crushed form, (C) Powdered form.**

Results and Discussions

Nowadays, syngas is one of the important sources for clean energy. It is a more efficient fuel than solid biomass because it mixes more easily with oxygen than solid biomass. Consequently, it can be used to directly generate heat and power, or be converted to several types of biofuels. Date palm seeds were used as a new substance to test this technology. In this work, different forms of date palm seeds were used, and different flow rates of ionize gas (Argon) were tested. Many gases were produced from the gasification process (Table 1 and Figure 4), but the focus was on CO production, which is considered as the main resource for biogas and renewable energy. Syngas production (CO) yielded a maximum rate from the first sample (full seeds), followed by the third sample (powdered seeds). The sample of crushed seeds yielded the least syngas (See Fig. 5). These results prove that date palm seeds do not need to any pre-treatment (milling) to improve biogas production, which is economically the best option. Full seeds have a higher percentage of gas-production because their milling causes internal cellulose and sugar loss.

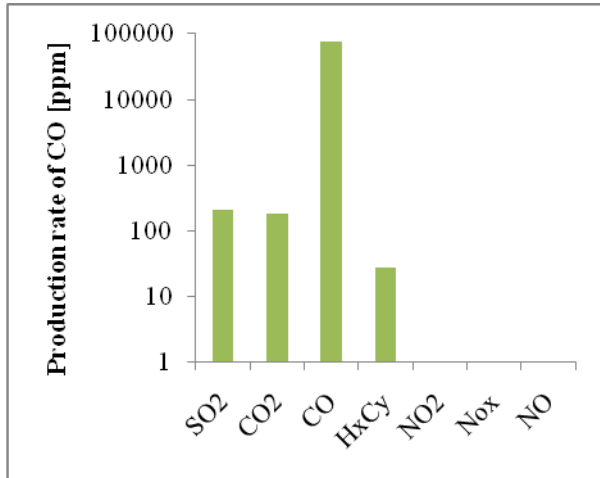

Fig (4) Production rate of gases from gasification

Chemical Component	Production rate [ppm]
Amb. (T) C ^o	18.7
Flue (T) C ^o	26.92
SO ₂	211.43
CO ₂	183.15
CO	76256.3
H _x C _y	26.92
NO ₂	0
No _x	0
NO	0

Table (1) Production rate of gases exit reactor

Fig (5) shows that the sample of full seeds reached a certain value of CO production, which remained stable for period of time, then the production started to reduce. The reason for this stable biogas is due to the sensor's reaching saturation point, which makes the peak of this curve indiscernible.

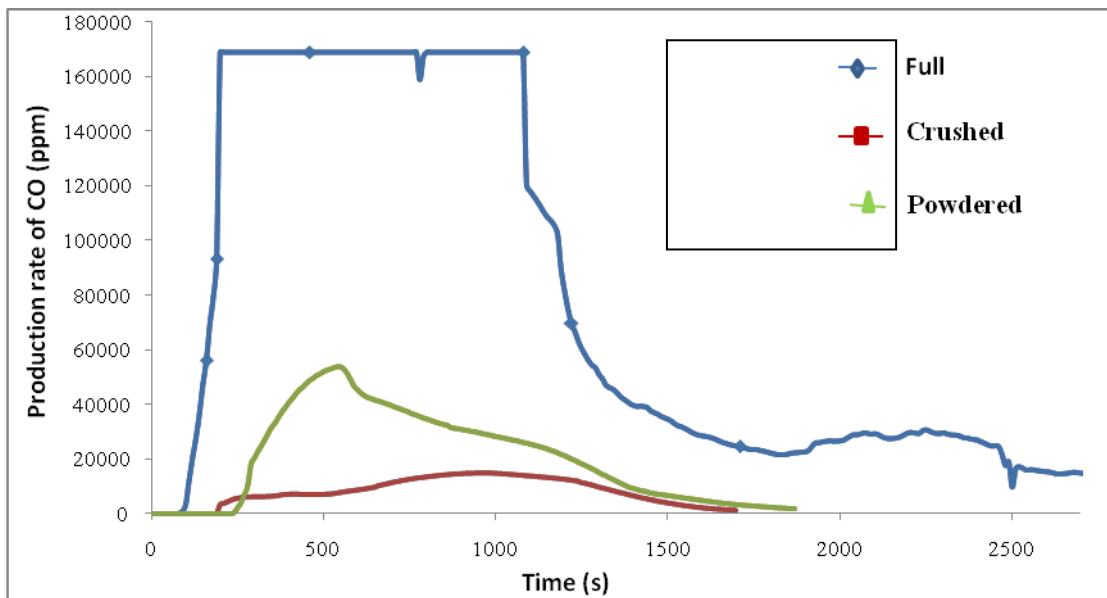

Fig (5) Production Rate of CO at 0.25 L/min of Argon for the Three Samples

Changing the flow rate of argon showed that the reduction of argon flow-rate causes CO production to increase (See Fig 6, 7, 8). Reducing the argon flow-rate increases plasma concentration, and renders it more pure.

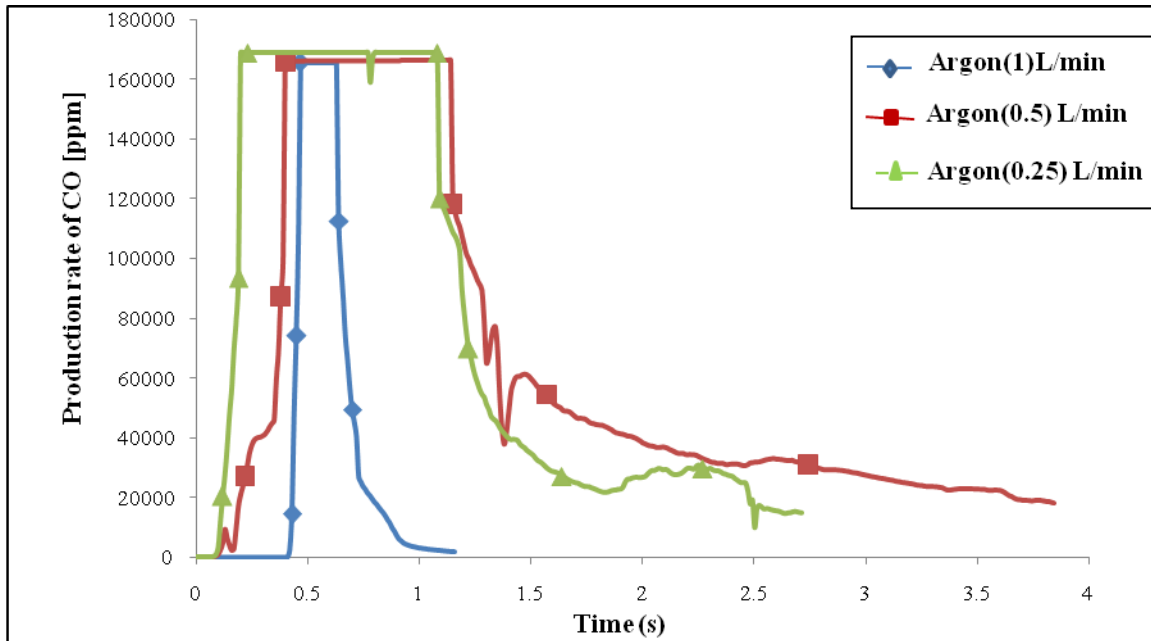

Fig (6) Comparison between different flow rates of argon. Sample of full seeds

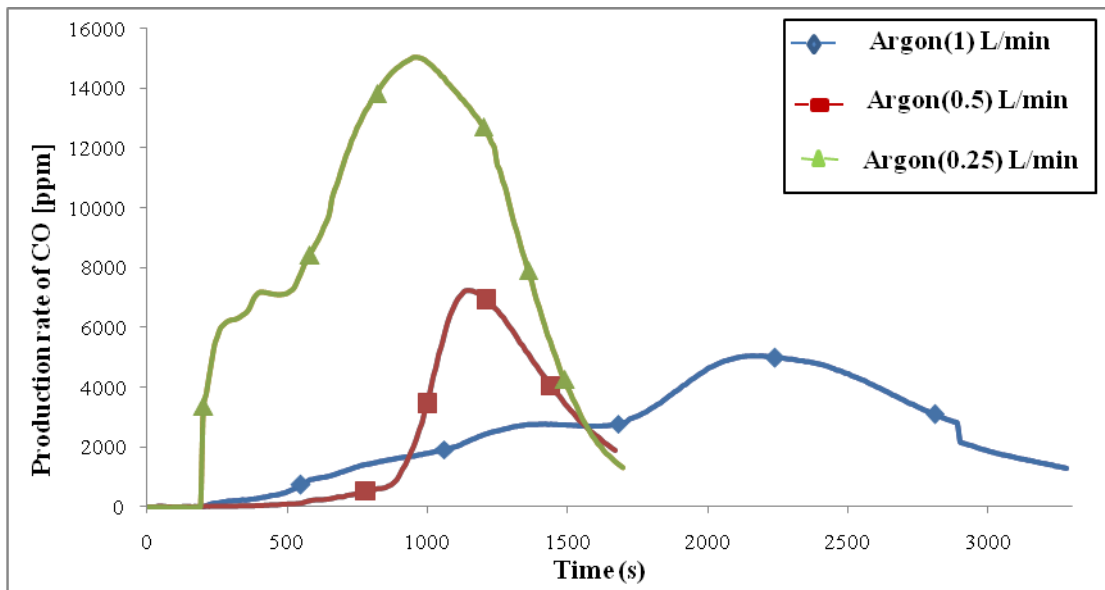

Fig (7) Comparison between different flow rates of argon. Sample of crushed

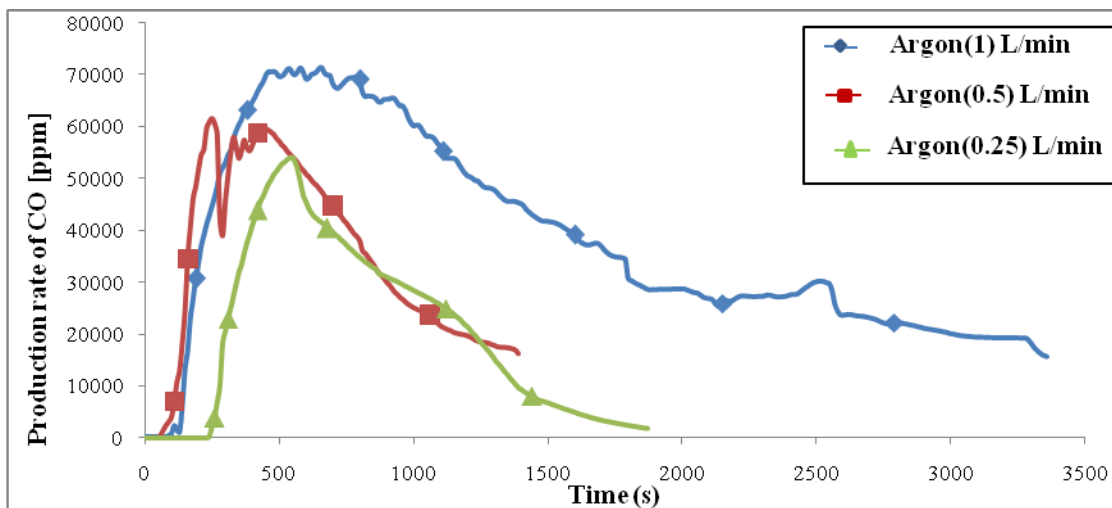

Fig (8) Comparison between different flow rate of argon. Samples of powdered

Conclusion

Dates are produced with high quantity in middle east and especially in Iraq. This research took the seeds of dates and tested by using plasma technology to appear how much energy can produce from them. Two parameters were change: form of seeds and flow rate of Argon. The results proved that date palm seeds with ordinary form and with minimum flow of Argon can produce a lot of energy or syngas compared with the other material such as wood, coffee hills, and in another hand the cost is lower because date palm seeds need little equipment's for pre-treatment and minimum material, which is best for economically point view.

References

- [1] Food and Agriculture Organization (FAO). www.fao.org .
- [2] Dominguez, Y. Fernandez, B. Fidalgo, J.J. Pis, and j. A. Menendez .(2007). "Biogas to Syngas by Microwave-Assisted Dry Reforming in the Presence of Char". J. American Chemical Society, vol. 21, pp. 2066-2071.
- [3] Gasification Technologies Council, 'Gasification: Redefining Clean Energy', available online: <http://www.gasification.org/> [accessed Oct 2010]
- [4] Mark Bricka, Dave C. Swalm, 'Energy Crop Gasification and Gasification Issues', School of Chemical Engineering Mississippi State University
- [5] Christopher Higman, Maarten van der Burgt, Gasification, Gulf Professional Pupliching, second edition 2008, pp. 12-15, 33-36
- [6] Linghong Zhang, Chunbao (Charles) Xu, Pascale Champagne. (2010). "Overview of recent advances in thermo-chemical conversion of biomass". L. Zhang et al. / Energy Conversion and Management, vol. 51, pp. 969-982.
- [7] Sandor Beszedes, Szabolcs Kertesz, Zsuzsanna Laszl, Cecilia Hodr, Gabor Szab. (2007). "Biogas production of ozone and/or microwave-pretreated canned maize production sludges". Conference IOA and Exhibition Valencia, pp. 1-6."
- [8] J. P. Robinson, S. W. Kingman, R. Barranco, C. E. Snape, and H. Al-Sayegh. (2010). " Microwave Pyrolysis of Wood Pellets ". J. American Chemical Society, vol. 49, pp 459-463.

- [9] Dennis A. and Burke P.E (2001) "Dairy Waste Anaerobic Digestion Handbook". Olympia, WA : Environmental Energy Company, pp.1.
- [10] B. Pound, Done F. and T. R. Preston. (1981). " Biogas production from mixtures of cattle slurry and pressed sugar cane stalk, with and without urea". Trop Anim Prod, vol. 6, pp. 1.
- [11] Momoh, O.L. Yusuf, Nwaogazie, L. Ify. (2008). " Effect of Waste Paper on Biogas Production from Co-digestion of Cow Dung and Water Hyacinth in Batch Reactors". J. Appl. Sci. Environ. Manage, Vol. 12 (4), pp 95 – 98.
- [12] M.F. Basri, S. Yacob, M.A. Hassan, Y. Shirai, M. Wakisaka, M.R. Zakaria, L.Y. Phang. (2010). " Improved biogas production from palm oil mill effluent by a scaled-down anaerobic treatment process". World J Microbiol Biotechnol, vol. 26, pp. 505–514.
- [13] Ir. H.A.M. Knoef. (2008). "BTG Biomass Gasification". Biomass technology group.
- [14] S. Eliezer & Y. Eliezer, The Fourth State of Matter, An Introduction of Plasma Science, 2001, IOP Publishing Ltd.